



ADAPTIVE NETWORK

SOLUTIONS

... smarter wireless connectivity

@ANY2400-SC-3

*2.4GHz IEEE802.15.4
RF Module with integrated
Power Amplifier and versatile
antenna diversity options*

-Preliminary Datasheet-

2011-December-5th
A.N. Solutions GmbH
Am Brauhaus 12
01099 Dresden



Content

1 GENERAL	3
1.1 APPLICATIONS	3
1.2 KEY FEATURES	4
2 OVERVIEW	4
2.1 ELECTRICAL CHARACTERISTICS	5
2.1.1 ABSOLUTE MAXIMUM RATINGS	5
2.1.2 RF CHARACTERISTICS	5
2.1.3 MICROCONTROLLER CHARACTERISTICS	5
2.2 PHYSICAL/ENVIRONMENTAL CHARACTERISTICS AND OUTLINE	6
2.3 MOUNTING INFORMATION	7
2.4 SOLDERING PROFILE	8
3 ORDERING INFORMATION	9



1 General

@ANY2400-SC-3 modules are full featured ultra-low power IEEE802.15.4/ZigBee™ RF module for the 2.4GHz ISM band based on ATMEL ATmega128RFA1 Single Chip solution and RFMD's RF6555 high featured FEM, complemented with on-board SPI flash option. This cutting edge module combines an exceptional receiving sensitivity and an optimal output power level in the smallest form factor utilizing antenna diversity operation via either ceramic antenna or one U.FL connected external antenna or via two U.FL connected antennas. @ANY2400-SC-3 modules are fully integrated solution that contains all the digital and analogue circuitry, required for tiny radio nodes.

The module eliminates the need for costly and time-consuming RF development, and shortens time to market for a wide range of standards based wireless products, while A.N. Solutions development kits AT-ANY-2400-SC-3 DESIGN ensure a fast validation, design and bring-up process.

1.1 Applications

@ ANY2400-SC-3 modules are flexible tools that can help realize standard or specialized functionality by utilizing different stack layers. The module provides ideal solutions for the following markets:

- Building automation and monitoring
- Industrial automation and monitoring
- HVAC and environmental control
- Security applications
- AMR/AMI
- Versatile customized solutions demanding wireless sensing capabilities

These and many other applications are realized using the following static and dynamic network topologies such as:

Point-2-Point communication

For point-2-point radio links, the application normally uses the HAL layer (Hardware Abstraction Layer) only and utilizes the minimum MCU flash and RAM. It can also access the radio on register level for squeezing out the optimal performance.

Star and Cluster-Tree communication

Cluster tree, Star or Point-2-Multipoint networks require some addressing scheme and a tight protocol to realize additional functionality, such as:

- Checksum proven and acknowledged data frame transmission
- Automatic frame retransmission
- Automatic children addressing

With additional firmware as ANS' Smart MAC Suite the above listed features can be used.

Mesh communication

Mesh networks can be realized with the help of Atmel's BitCloud ZigBee PRO. In a mesh network the addressing of all network nodes is done by the network layer in order to allow direct or relayed communication with all nodes in the network. Route detection and frame delivery is supported following the AODV algorithm (Ad-hoc On-demand Distance Vector).

Moreover additional other commercial and non-commercial IEEE 802.15.4 compliant networking stacks are applicable such as:

- 6LoWPAN
- Wireless Hart
- SNAP by Synapse Wireless



1.2 Key features

- Compact size (41 x 13.5 x 3.0) mm
- Receiver sensitivity up to -121dBm (RFA+LNA)
- Up to 18dBm scalable output power (RFA+PA)
- Low power consumption at all operational stages
 - TX: < 85mA @18dBm
 - RX: < 22mA
 - Idle: < 5mA
 - Sleep: < 10uA
- Antenna diversity as standard operation
- Fully integrated chip antenna with best in class module performance
- 128K(256k)²⁾ bytes of flash memory, 16K bytes RAM, 8K bytes Eeprom
- Supply monitoring via ADC
- Wide range of interfaces (both analogue and digital):
 - 9 spare GPIO, 2 spare IRQ lines
 - 4 ADC lines
 - 2 USART, TWI, SPI, 1-Wire
 - Up to 30 lines configurable as GPIO
 - Capability to write own MAC address into the EEPROM
- Fully IEEE 802.15.4 compliant
- 2.4GHz ISM band (integrated antenna or U.FL antenna version selectable by order code)
- Runs BitCloud (Zigbee Pro Feature Set) unchanged ³⁾
- Compatible with Atmel's module platform for ZigBee Pro ³⁾
- Other IEEE 802.15.4 complaint networking solutions applicable
- Compliant to radio certification standard EN300328 ⁽¹⁾ and FCC CFR Part 15 ⁽¹⁾

(1) Manufacturer declaration of conformity in progress, certification on customized design platforms planned
(2) Customized assembly option using ATmega256RFA-1 on request
(3) Additional library needed

2 Overview

The @ANY2400-SC- 3 modules contains Atmel's System-On-Chip ATmega128RFA1, RFMD 6555 integrated FEM as well as an on-board SPI flash 2Mbit of size.

A.N. Solutions offers two modules, which differentiate in the output connectivity. The @ANY2400-SC-3-1 module is equipped with a ceramic antenna and one U.FL connector for diversity operation and the @ANY2400-SC-3-2 module provides two U.FL ports to connect external antennas. Several ports are routed to the edge of the module's carrier PCB, such as GPIOs, power connections, and more. See Figure 1 for an overview of the module's contents.

By default, the module is sold without the downloadable firmware "Smart MAC Suite" from www.an-solutions.de. Different delivery options may be realized on customer demand.

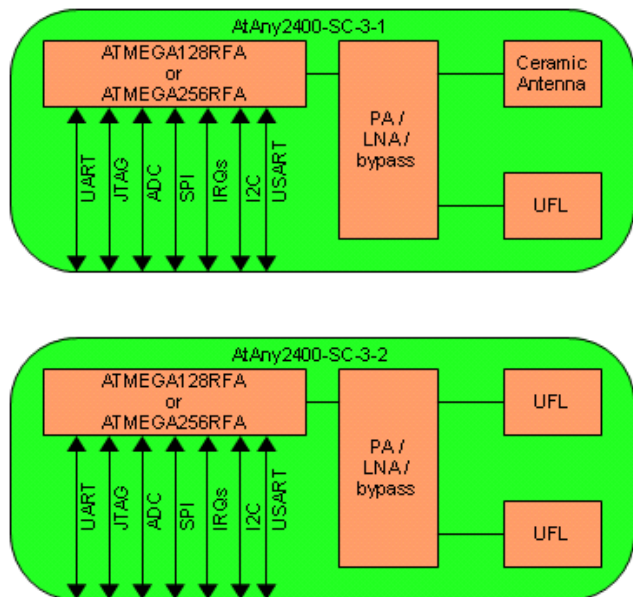

Figure 1 Module contents of @ANY2400-SC-1 and @ANY2400-SC-2



2.1 Electrical Characteristics

2.1.1 Absolute Maximum Ratings

Table 1 Absolute maximum ratings

Parameters	Min	Max
Voltage on any pin	0V	3.6V
DC Current per I/O Pin		40mA
DC Current DVCC and DGND pins		300 mA
Input RF Level		+5 dBm

Notes:

- Values stated in Table 1 are such values, when the device may be damaged permanently if exposed to them. The device will not work correctly at the given values or beyond.
- The @ANY2400-SC-3 devices are ESD-sensitive. Handle carefully to prevent ESD damages

2.1.2 RF Characteristics

Table 2 typical RF characteristics at VDD = 3.3V

Parameters	Range	Unit
Frequency Band (5MHz spacing)	2410 .. 2475	MHz
Number of Channels	14	
Transmitter Output Power (SW controllable, +/-2.5dB)	-16.5 to +18	dBm
<i>Receiver Sensitivity, AWGN channel, PER = 1%:</i>		
<i>With PSDU length of 20 octets</i>		
250 kbit/s ⁽²⁾	-111	dBm
500 kbit/s ⁽²⁾	-107	dBm
1000 kbit/s ⁽²⁾	-105	dBm
2000 kbit/s ⁽²⁾	-97	dBm
TX Output/ RX Input Nominal Impedance For balanced output	50	Ω

Notes:

⁽¹⁾ Preliminary data

⁽²⁾ IEEE 802.15.4-2006 compliant

2.1.3 Microcontroller Characteristics

Table 3 Microcontroller characteristics

Parameters	Range	Unit
On-chip Flash Memory size	128	kbytes
On-chip RAM size	16	kbytes
On-chip EEPROM size	8	kbytes
Operation Frequency	16	MHz

2.2 Physical/Environmental Characteristics and Outline

Table 4 Environmental characteristics

Parameters	Value	Comments
Size	41 x 13.5 x 3.0 mm	AT-ANY2400-SC-3
Operating Temperature Range	-20°C to +70°C	-40°C to +85°C operational ⁽¹⁾
Operating Relative Humidity Range	no more than 80%	

Note: ⁽¹⁾ Minor degradation of clock stability may occur.

Figure 2 @ANY2400-SC-3 Mechanical drawing

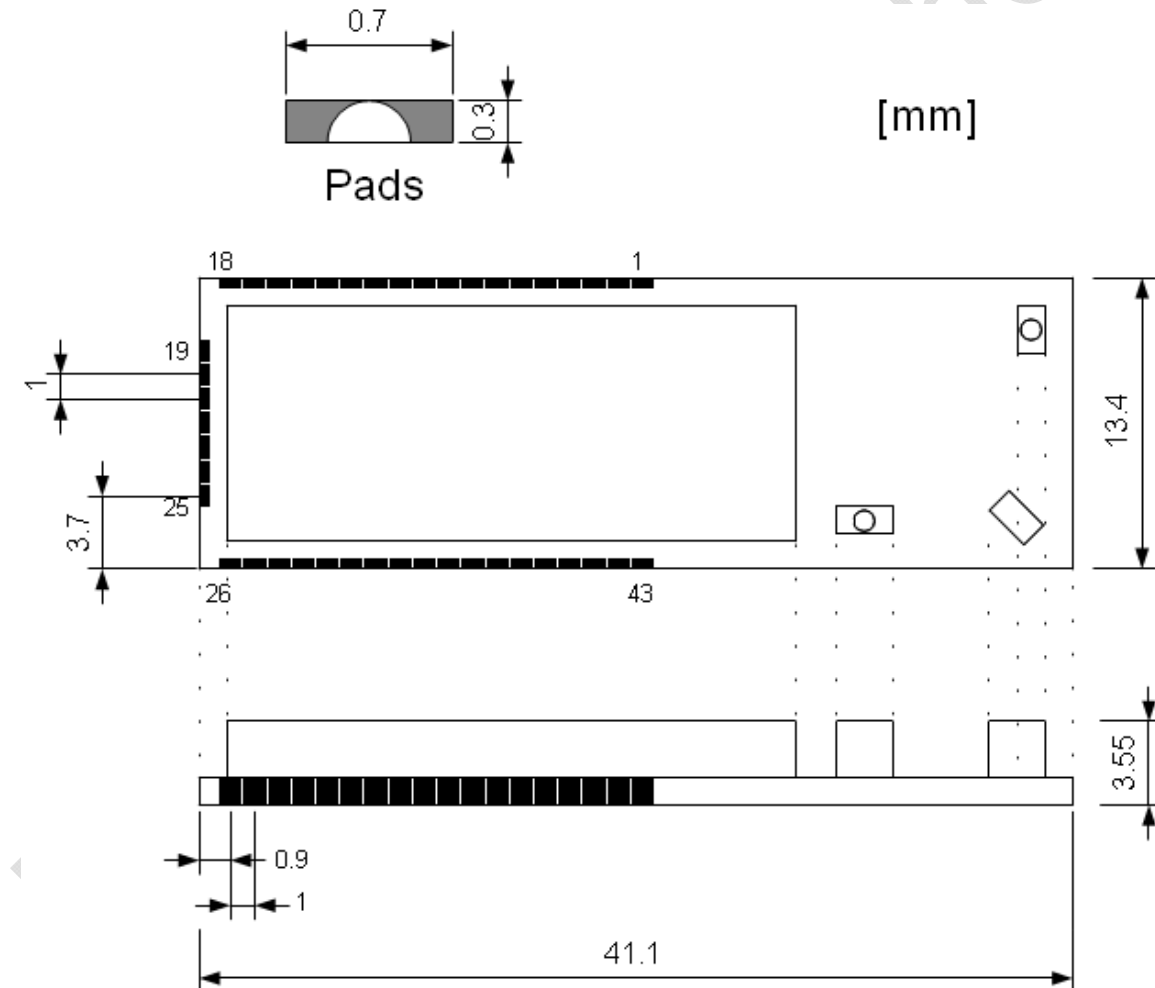



Table 5 Pin description

#	I/O	Description	#	I/O	Description
1	I	RESET	23	I ^{e)}	GPIO3
2	I/O ^{e)}	DIG3	24	I/O ^{e)}	GPIO4
3	I/O ^{e)}	DIG1	25	O ^{e)}	USART0_RXD
4	I/O ^{e)}	AMR	26	I ^{e)}	USART0_TXD
5	O	CLKOUT	27	I ^{e)}	USART0_EXTCLK
6	I	VDD33	28	I/O ^{e)}	GPIO5
7	I	VDD33	29	I/O ^{e)}	GPIO6
8	I	GND	30	I ^{e)}	UART1_DTR
9	I ^{e)}	SCL	31	I ^{e)}	INT6
10	I/O ^{e)}	SDA	32	I ^{e)}	INT7
11	O ^{e)}	UART1_RXD	33	I ^{e)}	ADC0
12	I/O ^{e)}	UART1_TXD	34	I ^{e)}	ADC1
13	I ^{e)}	UART1_CTS	35	I ^{e)}	ADC2
14	O ^{e)}	UART1_RTS	36	I ^{e)}	ADC3
15	I/O ^{e)}	GPIO7	37	I ^{e)}	TCK
16	I/O ^{e)}	GPIO8	38	I ^{e)}	TMS
17	O ^{d)e)}	SSN	39	O ^{e)}	TDO
18	O ^{d)e)}	SCK	40	I ^{e)}	TDI
19	O ^{d)}	MOSI	41	I	GND
20	I ^{d)}	MISO	42	I	XTAL1
21	I/O	GPIO0	43	I	AREF
22	I/O	GPIO2			

Notes:

- a) The UART_TXD pin shall be used as data input for using @ANY2400-3 as its RF terminal unit. UART_RXD pin shall operate as output.
- b) Most signals can be configured as I/O pins with or without internal pull-up resistor.
- c) Using ferrite bead and 1 μ F capacitor located closely to the power supply pin is recommended.
- d) For master mode
- e) Software configurable

2.3 Mounting Information

Several factors may affect the proper operation, such as the environment surrounding the module and especially the antenna. The module's antenna is a ceramic design, which provides a radiating structure if the environment and design does not change the near-field of the antenna with metallic or capacitive elements. The critical area is limited by about two to four wavelengths, which is roughly in a radius of 0.7 meters.

Following these tips will improve the radiating performance:

- Avoid metal as much as possible
- Avoid placing high profiled elements close to the antenna
- Placing many thin vias through all the carrier PCB connecting metal to ground helps avoid resonance effects and provide a low impedance connection to ground potential
- Place RF parts far off from switching circuitry to avoid intermodulations
- Metalize board edges on top and bottom layer and place vias there to connect the layers for eliminating board edge radiations

For a proper PCB layout:

- Keep fast switching signals as far away as possible from the non-shielded area
- Remove any metal below and around the antenna section
- Place the module at the edge of your carrier board
- Use ferrite beads on power supply lines for proper and stable RF radiation
- Vias and wires below the module are NOT allowed
- Connect RF ground pins to low ohmic ground, place vias right next to the pin connection if needed

Figure 3 Footprint description for PCB layout

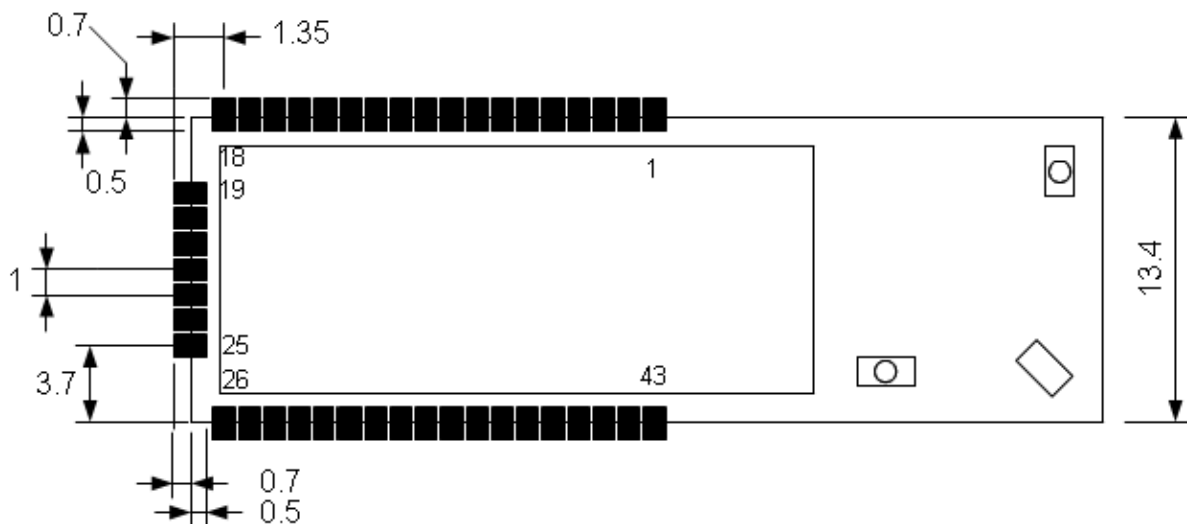



2.4 Soldering Profile

As module parts RoHs and Reach compliant the J-STD-020D-compliant soldering profile is recommended.

Table 6 J-STD-020D Profile

Feature	Green Package
Average ramp-up rate (217 °C to peak)	3 °C/s max.
Preheat temperature 175 °C ± 25 °C	180 s max.
Temperature maintained above 217 °C	60 s to 150 s
Time within 5 °C of actual peak temperature	20 s to 40 s
Peak temperature range	8 minutes max.
Ramp-down rate	6 °C/s max.

Note: The package is backward compatible with Pb/Sn soldering profile

Figure 4 EMS Reference soldering profile

SuperM.O.L.E.(r) Gold SPC V5.22aa - kundenspez_Profile.mpc
 Id. Datei: SM_E91824_DDD1D4 Datum: 24/01/07

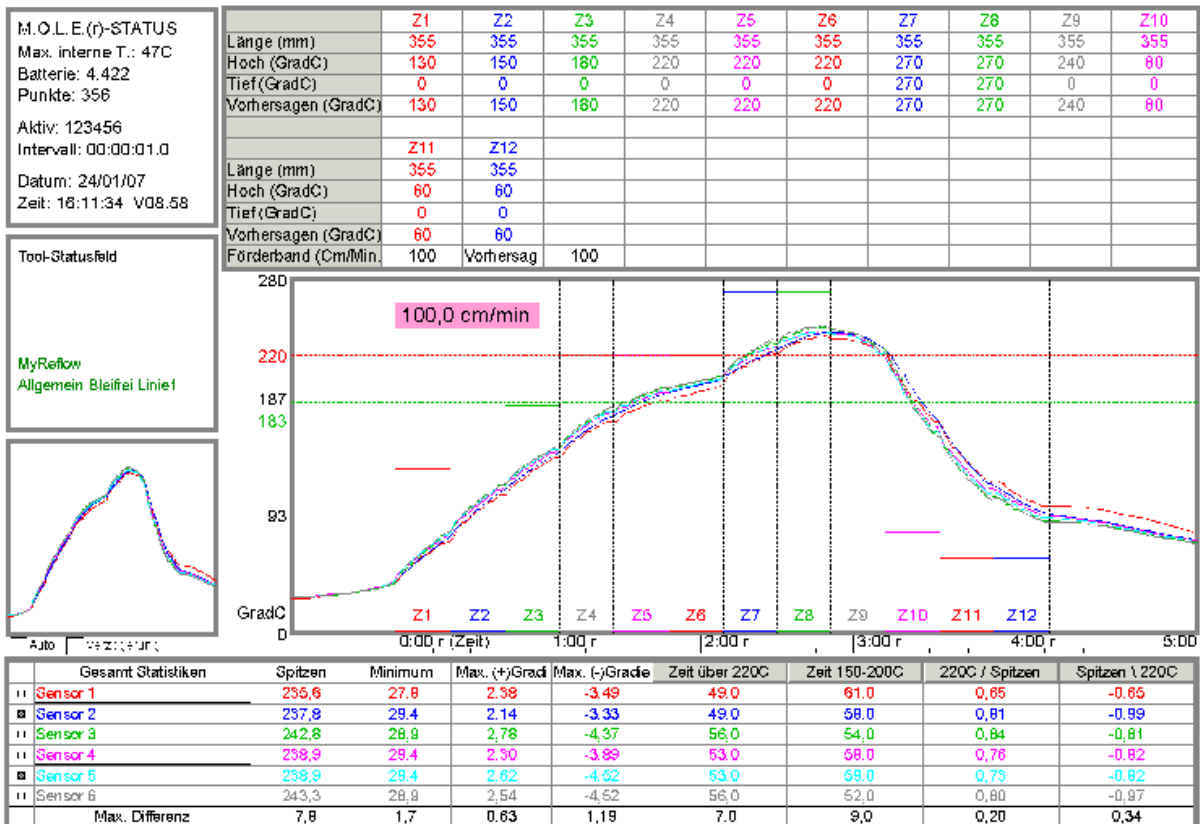



3 Ordering Information

Part number: @ANY2400-SC-3-1 with ceramic antenna and one U.FL connector
@ANY2400-SC-3-2 with two U.FL antenna connectors

Description: IEEE802.15.4-2.4GHz Single Chip PA module

Shipping variants: Samples available on request

Disclaimer

A.N. Solutions believes that all information is correct and accurate at the time of issue. A.N. Solutions reserves the right to make changes to this product without prior notice. Please visit A.N. Solutions website for the latest available version.

A.N. Solutions does not assume any responsibility for the use of the described product or convey any license under its patent rights.

A.N. Solutions warrants performance of its hardware products to the specifications applicable at the time of sale in accordance with A.N. Solutions standard warranty. Testing and other quality control techniques are used to the extent A.N. Solutions deems necessary to support this warranty. Except where mandated by government requirements, testing of all parameters of each product is not necessarily performed.

Trademarks

AT-ANY, @ANY and related naming as well as A.N. Solutions logo are trademarks of A.N. Solutions GmbH. All other product names, trade names, trademarks, logos or service names are the property of their respective owners.

Technical Support

Technical support is provided by A.N. Solutions GmbH on demand and in accordance to service conditions agreed.

E-mail: support@an-solutions.de

Please refer to Support Terms and Conditions for full details.

Contact Information

A.N. Solutions GmbH

Am Brauhaus 12
01099, Dresden,
Germany
Tel: +49 351 8134 228
Fax: +49 351 8134 200

Office hours: 8:00am - 5:00pm (Central European Time)

© 2011 A.N. Solutions All rights reserved.

No part of the contents of this manual may be transmitted or reproduced in any form or by any means without the written permission of A.N. Solutions.